

**ADLER**

INSTRUCTION HANDBOOK



## *Writing on J 2 or J 4*

In buying your portable typewriter you have chosen well. The following operational instructions are intended to serve you as guide enabling you to fully enjoy the various advantages offered by this typewriter. The essential points to be observed when typing with "J 2" or "J 4" are briefly described hereafter.

Confide in "J 2" or "J 4". The machine will show you everything by itself.



Many of you certainly will know our portable typewriters already, but the following hints will help you to become better acquainted with it.

You will find:	Page	Page	
Bottom plate . . . . .	8	Line space lever . . . . .	18
Carriage lock . . . . .	9	Carriage release lever . . . . .	18
Paper rest . . . . .	10/11	Platen release . . . . .	19
Paper bail . . . . .	10/11	Line finder . . . . .	20
Paper guide . . . . .	11	Card holder . . . . .	20
Paper release . . . . .	12	Ribbon . . . . .	21
Paper support . . . . .	13	Ribbon reverse switch . . . . .	21
Paper support with terminal indicator . . . . .	14	Ribbon position indicator . . . . .	22
Margin stop . . . . .	15	Stroke regulator . . . . .	22
Line space regulator . . . . .	15	Tabulator . . . . .	23
Keyboard . . . . .	16/17	Tabulator set and clear key . . . . .	23
		Service and maintenance . . . . .	24

## Survey of the various service parts of "J2"

- |                                      |                                 |
|--------------------------------------|---------------------------------|
| 1 Space bar                          | 15 Scale                        |
| 2 Left and right shift key           | 16 Paper discharge guide        |
| 3 Shift lock                         | 17 Paper holder                 |
| 4 Marginal release                   | 18 Paper support                |
| 5 Ribbon indicator                   | 19 Line finder with card holder |
| 6 Ribbon reverse switch              | 20 Right margin stop            |
| 7 Line space lever                   | 21 Stops                        |
| 8 Carriage lock                      | 22 Paper rest                   |
| 9 Platen knob                        | 23 Paper release                |
| left side variable line space device | 24 Platen                       |
| 10 Carriage release                  | 25 Ribbon spool                 |
| 11 Line space regulator              | 26 Tabular set and clear key    |
| 12 Platen release                    | 27 Back spacer                  |
| 13 Left margin stop                  | 28 Tabular key                  |
| 14 Left hand paper guide             |                                 |

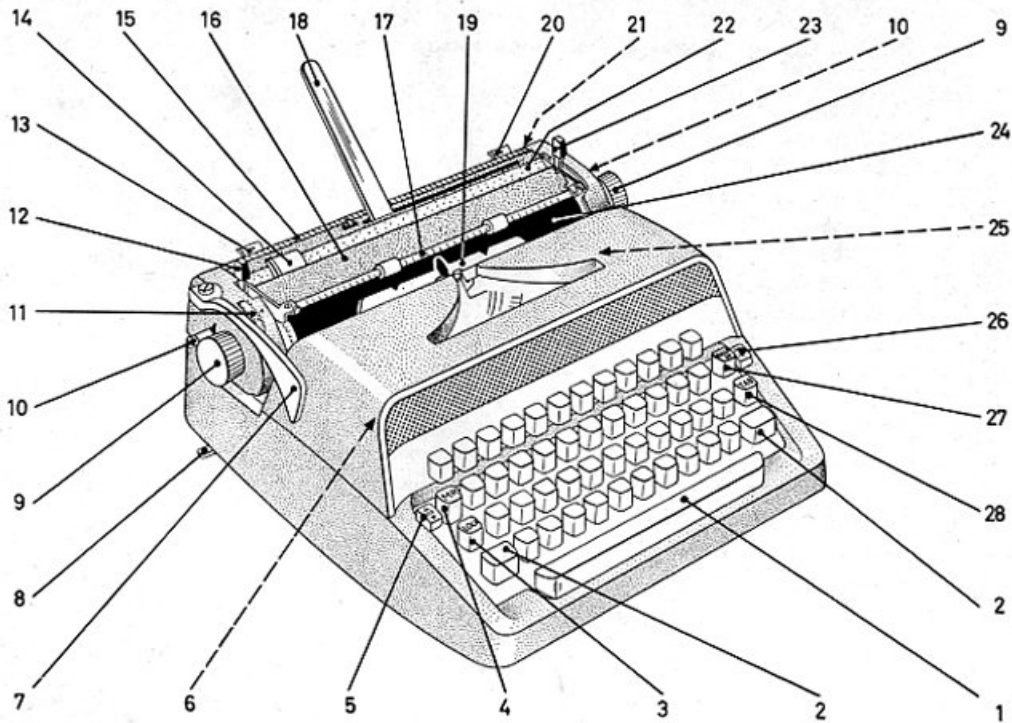

## Survey of the various service parts of "J 4"

- |                                      |  |
|--------------------------------------|--|
| 1 Space bar                          | 15 Scale                                 |
| 2 Left and right shift key           | 16 Paper discharge guide                 |
| 3 Shift lock                         | 17 Paper holder                          |
| 4 Marginal release                   | 18 Paper support with terminal indicator |
| 5 Ribbon indicator                   | 19 Card holder                           |
| 6 Ribbon reverse switch              | 20 Line finder                           |
| 7 Line space lever                   | 21 Right margin stop                     |
| 8 Carriage lock                      | 22 Stops                                 |
| 9 Platen knob                        | 23 Paper rest                            |
| left side variable line space device | 24 Paper release                         |
| 10 Carriage release                  | 25 Platen                                |
| 11 Line space gauge                  | 26 Ribbon spool                          |
| 12 Platen release                    | 27 Tabular set and clear key             |
| 13 Left margin stop                  | 28 Back spacer                           |
| 14 Left hand paper guide             | 29 Tabular key                           |

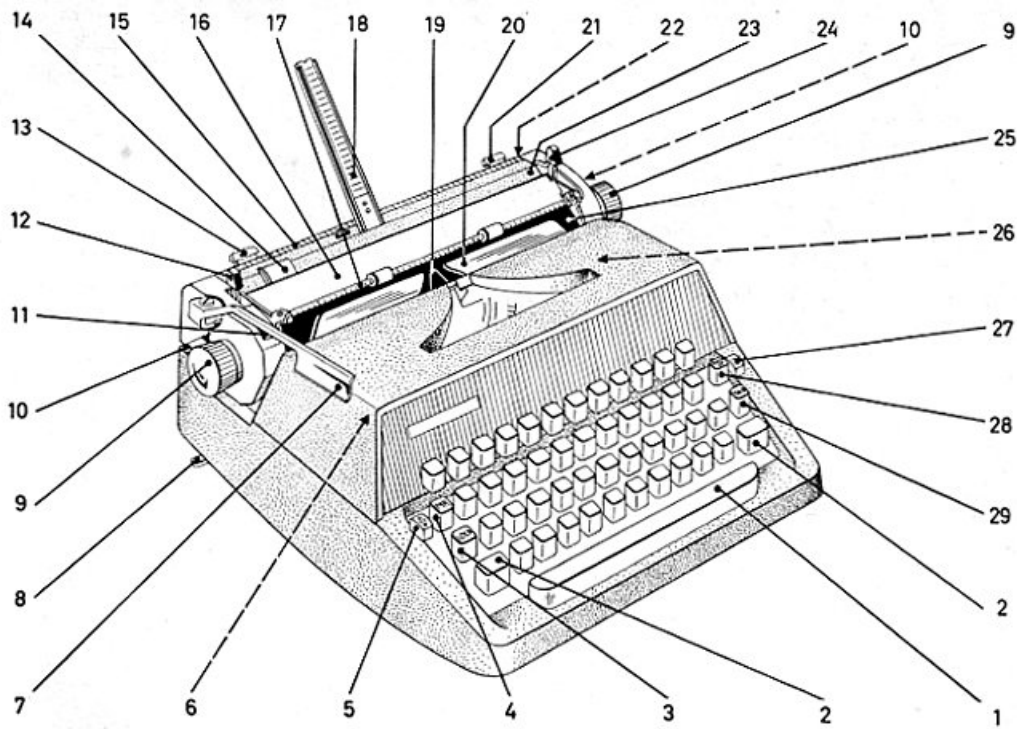



## J 2 + J 4

Of course you may also type on your machine when the same is only half unpacked, viz. by simply removing the cover. However, you may also take off the bottom plate. Simply push back the two snap levers and you will be able to lift off your typewriter.

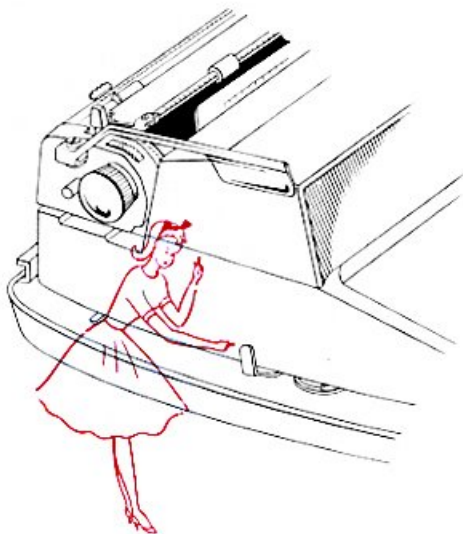

J 2 + J 4

**It does not move?**

This is not necessary, for it is not supposed to have "its own way of doing things", as long as you do not type on it. Pull forward the small lever on the left hand side locking the carriage, and your typewriter is ready for action.

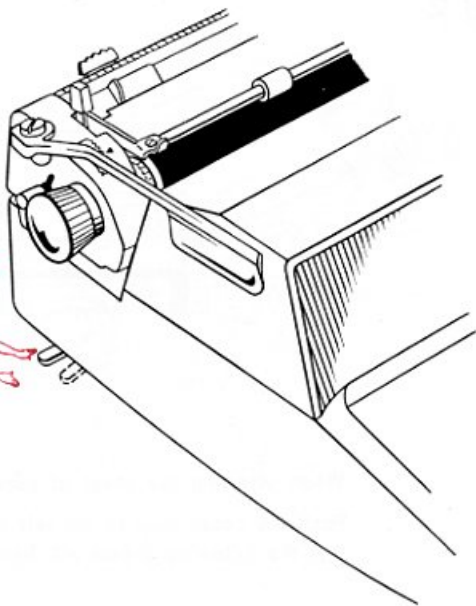

J2

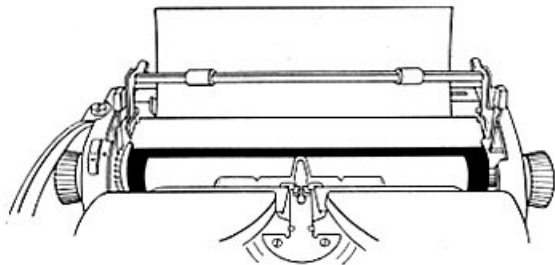

**When inserting the sheet of paper also raise the paper ball.**

**Push the paper stop to the left margin of your sheet of paper, so that the following sheets will have the same position.**

The sheet of paper automatically goes under the rollers of the paper holder when inserting same. Push the paper stop to the left margin of your sheet of paper, so that the following sheets will have the same position.

J 4

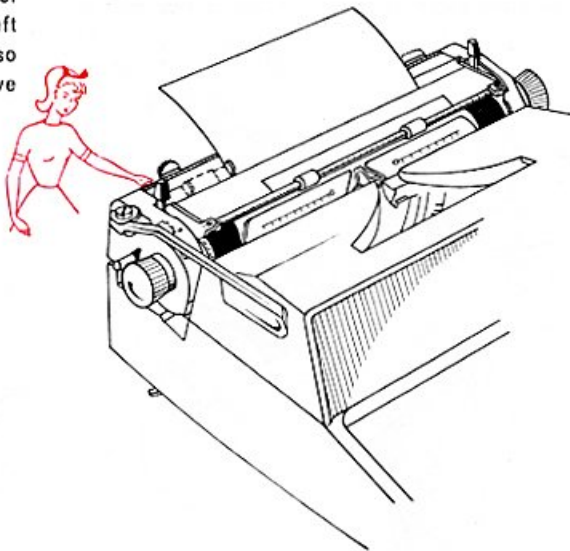

Should the sheet of paper not have its correct position then the paper release will help you. Adjust your sheet of paper properly in accordance with the horizontal line setter. It also corresponds exactly with the base line of your typing line. Do not forget to push back the paper release as soon as this adjustment has been completed.

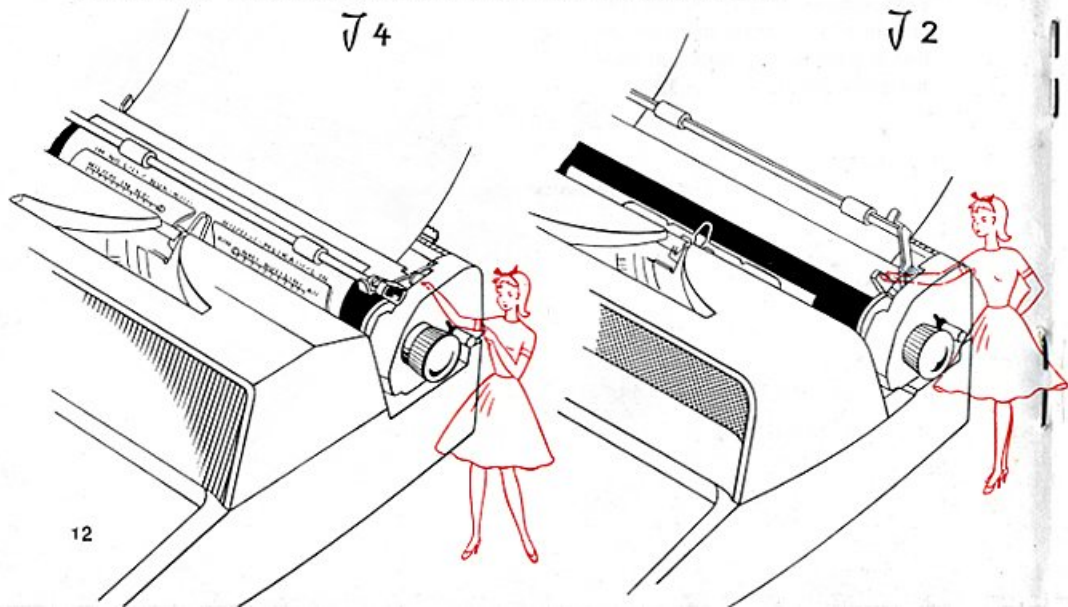

Bring the paper support upwards when typing, it will prove to be very useful.

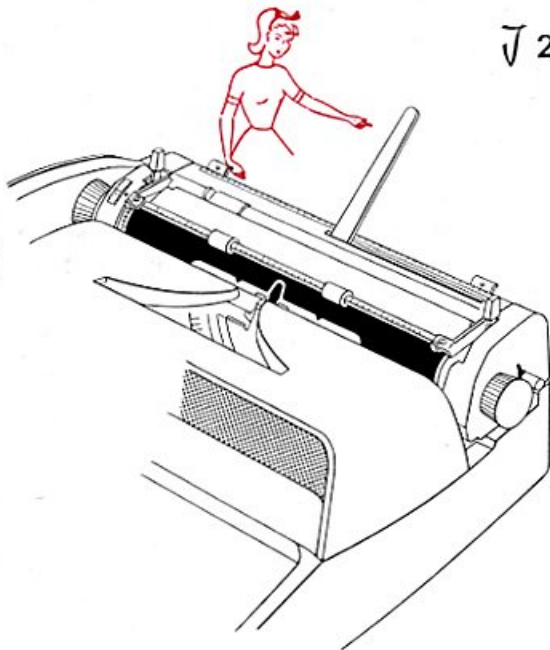

J 4

By simply striking the release lever, the paper support jumps into its position. On the terminal indicator which can be pulled out you will see different markings. Whenever the top of the sheet of paper reaches a certain marking this will indicate that the lower end of the sheet has been reached — taking into account, of course, a suitable margin.

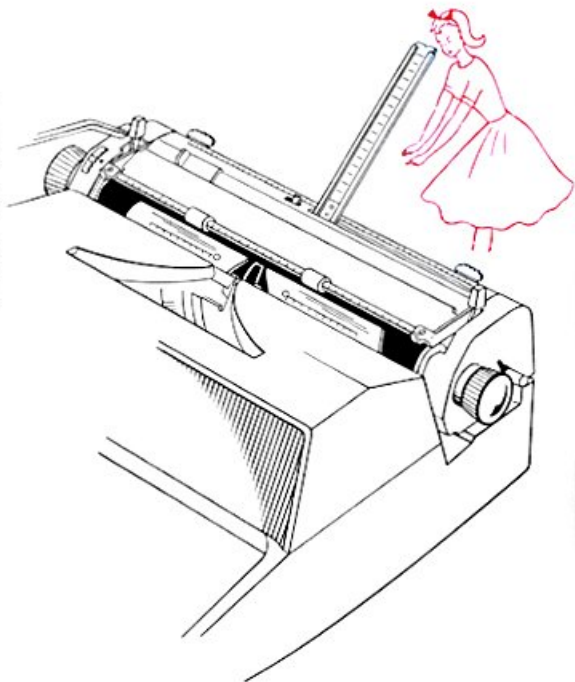

**This is important:**

You will most certainly want that your letters get that personal touch. This depends on how you distribute the type on the sheet of paper. The two margin sets help you as to the limitation of the length of a line; the line spacer accounts for the even space between the lines. With it you can set one, one and a half and twofold space between the lines. The adjusted length of a line you control on the scale of the paper holder. On the scale of the paper holder is in agreement with the scale of the margin placer.

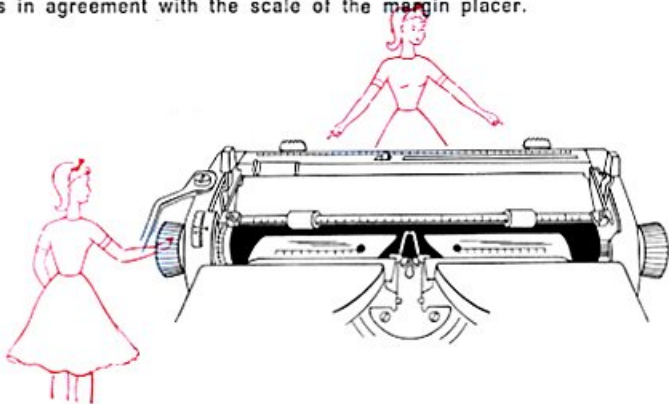



✓ 2 + ✓ 4

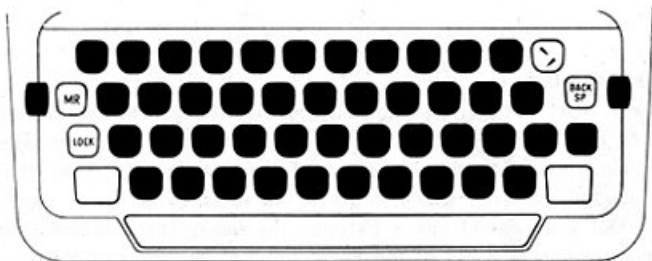

**Before starting — a swift glance on your keyboard:**



**Marginal release** — strike the key when you wish to write outside of the length of line set, viz. before the beginning of the line or after its end.



**Back spacer** — it moves the carriage one notch towards the right.



Shift key — left and right, for capital letters and signs (special characters).

∩ 2 + ∩ 4



Shift key lock — for continuous shift, pressing down the left shift key will release it.



Dead key (accentkey) — has to be struck before the letter carrying the accent. The accent ^ (circumflex) may be obtained by combining the simple accents / and \ .

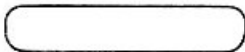

Space bar — for intermediate spacing and letter spacing.

### Correcting Space Bar?

Omitted letters can easily be filled in, e. g.

ADLER WRKE FRANKFURT  
ADLER WERKE FRANKFURT

Keep the space bar in a pressed position and type the first letter. Then let go of the space bar, repress it and type the next letter and so on. With the same method you can reach the margin balance at the end of a line, too.

✓ 2 + ✓ 4

**Now go to work with courage  
and good faith!**

Each time when you strike a key the carriage moves one notch towards the left. Eight strikes before the end of a line the bell sounds — then it is about time to finish this particular line.

By manipulating the line space lever you will attain the next line of writing. — The carriage may be pushed left or right by means of one of the two carriage release levers.

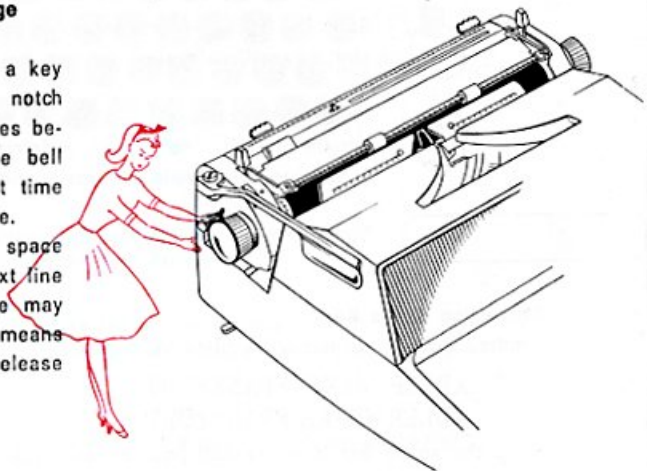

For instance if you wish to type a lined blank or sheet of paper simply pull out the left platen knob; thus the platen may be turned independantly of the original line spacing. Turn the platen until the line to be written is even with the line on the scale of the line setter, and push back the left platen knob.

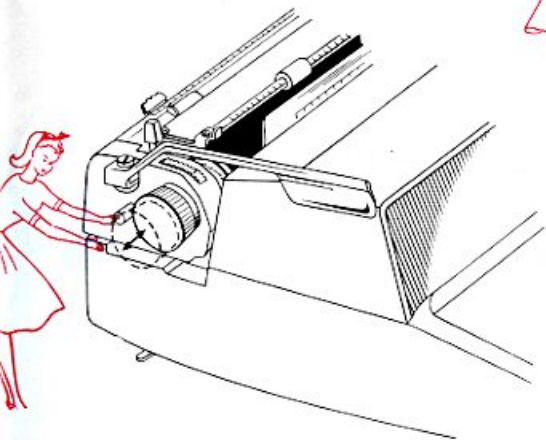

By pulling the platen release lever towards the front the platen turns freely. As soon as the platen release is returned to its starting position the original line rhythm will be restored.

J 2 + J 4

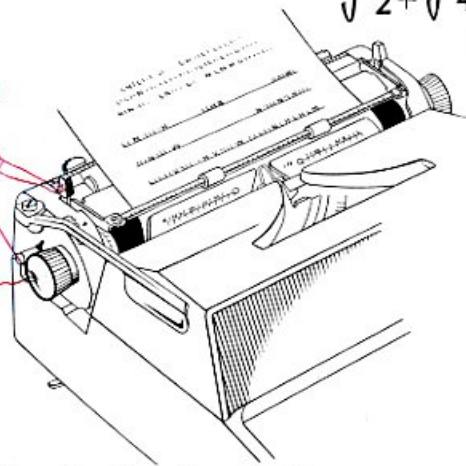

You can also draw lines. Place a pencil into the notch of the left or right line setter — pull the carriage release towards the front — and move the carriage either way; you will have a horizontal line. If you want to obtain vertical lines pull the carriage release forward and turn the platen.

J 2

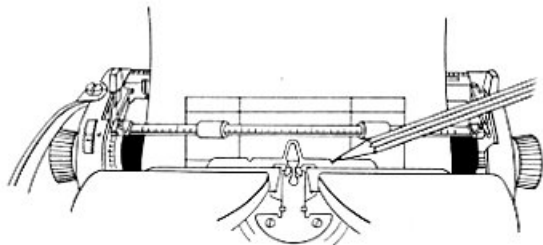

J 4

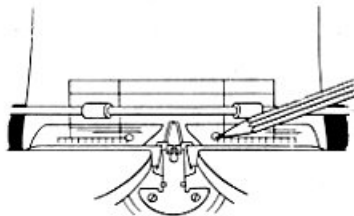

As far as the ribbon is concerned this is a simple affair. Normally it does not need any attention, for your typewriter takes care of it itself watching that it spools off regularly.

When replacing a ribbon lift the ribbon cover by a slight pull upwards. When you swing out the brake lever you will be able to remove the ribbon. Now all that remains for you to do is to insert the new ribbon into the ribbon fork as illustrated below. The two ribbon reverse switches allow you to adjust the movement of the ribbon either way.

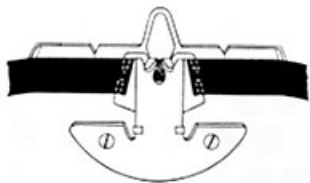

∩ 2 + ∩ 4

You can also use a bicolor ribbon, for instance black/red. Insert the ribbon in such a way that the black part will be on top. With the ribbon adjuster you will be able to obtain three settings:

direction of arrow white: for typing stencils.

center position blue: the ribbon is set on the upper half.

direction of arrow red: the ribbon is set on the lower half.

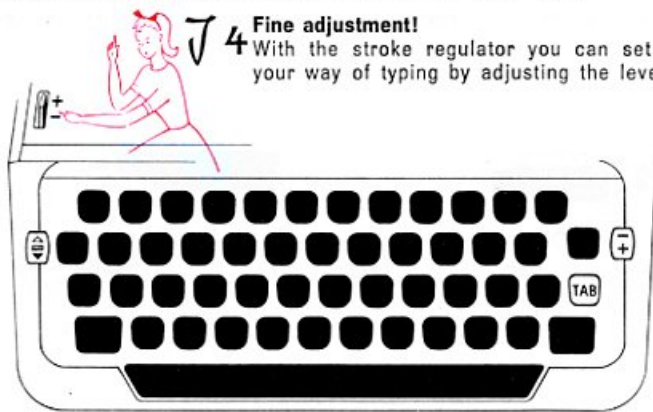

When typing tables, columns or lists etc. the tabulator offers special advantages. Your machine is equipped with so-called "stops" by means of which any desired position of a line may be obtained upon striking the tabulator key.

Previously, however, the stop has to be set. Move the carriage to the spot where you wish to set a stop and now push the tab. set and clear lever in the direction marked by the + sign. This operation may be repeated as often as necessary. Now you can start... strike the tabular key... and the carriage will stop at the designated position.

Perhaps, a stop is to be set one notch further to the left... this is quite simple.

Move the carriage over to the wrong position of the stop and push the set and clear lever in the direction marked by the — sign. Now the tabulator is "cleared", and it can be reset correctly. Whenever you wish to clear all stops simultaneously simply push the carriage to the right until stop. Now press the set and release lever in the direction marked by the — sign and simultaneously press the tabular key. During the movement of the carriage to the left all set tabulators are cleared.





$\sqrt{2} + \sqrt{4}$

**A wish!**

Never forget that your typewriter also needs a certain amount of maintenance. It already begins when you first start typing. Never abuse your typewriter. For erasing push the carriage all the way to the left or right in order to prevent the dust developed from dropping into the machine. Clean the keys from time to time by brushing them lengthwise on the face of the keys. Your typewriter will be grateful for it and show its gratitude by giving good and reliable service.

Any further questions and problems will be answered by your

**A D L E R dealer.**

99 a

**ADLERWERKE AG. FRANKFURT/MAIN**